

# MAXIMISER Semi-Storage Calorifiers



# Introduction

THE RYCROFT MAXIMISER HAS BEEN DEVELOPED TO MEET TODAY'S NEED FOR A COMPACT CALORIFIER WHICH WILL RESPOND TO HIGH PEAK LOADS WITH MINIMAL DEMAND FOR BOILER POWER. THIS HIGH OUTPUT SEMI-STORAGE CALORIFIER IS THE ULTIMATE SOLUTION TO SPACE LIMITATIONS, POWER REGULATION, FLUCTUATIONS IN DEMAND AND ENERGY SAVINGS.

The Rycroft Maximiser is a semi-storage calorifier equipped with an in-built non-storage heat exchanger. The baffled heat exchanger with a 2-pass shell provides an efficient compact unit which is considerably smaller than a conventional storage heater battery.

An integral pump circulates secondary water between the storage section and the heat exchanger. The interconnecting pipes are so arranged that the entire volume quickly reaches full storage temperature. **This not only assures a maximum reserve of hot water but also eliminates any areas of cool water, which may promote the growth of Legionella pneumophila.**

The maximum demand from the boiler can be regulated by adjusting the circulation rate through the heat exchanger and offers a flexibility of control not possible with a simple storage battery. Demands for hot water are promptly sensed by the control system which immediately starts the heat recovery process. Low draw off rates only require low demands from the boiler service. High draw-off rates can only generate a demand from the boiler equal to the limit by the Maximiser control.

The reserve of stored water provides the extra supply of hot water required for peak flows and the heat exchanger continues to make up the loss after the surge has ended.

## How it Works

The Maximiser has a fixed speed centrifugal pump which circulates secondary water through the heat exchanger and into the storage cylinder. The flow rate through the heat exchanger is set above the calculated peak hourly demand. The heat exchanger is sized to raise the temperature of the secondary water from cold to design temperature in a single pass through the exchanger.

When the unit is first commissioned the content is cold. The pump draws water from the bottom and returns it hot through the spreader into the top half of the cylinder. Here the hot water mixes with the cold storage, gradually raising the entire contents to the design temperature.

When the demand for hot water is less than the peak hourly rate the cold feed is drawn directly into the heat exchanger by the pump together with some hot water from the bottom of the cylinder. The water passing through the exchanger is already partially warmed and only sufficient heat is added to reach the design temperature.

When the demand for hot water exceeds the pump rate, cold feed is still drawn into the heat exchanger but the excess cold feed enters the bottom of the cylinder without disturbing the layer of hot water above. The heat exchanger now generates hot water at the maximum design rate and flow from the cylinder outlet is supplemented by hot water from the storage section.

After a heavy demand the heat exchanger continues to work at high output until the storage temperature in the bottom of the cylinder is restored.

In order to make full use of the stored hot water it is advisable to fit a non-return valve on the secondary return. This will prevent

cold water entering the secondary system via the return leg. It will be appreciated that even under severe overload conditions the heat exchanger will maintain full power output giving a moderate mix temperature until such time as normality returns.

- The Maximiser is able to handle peak flow rates in excess of its hourly rating without overloading the boiler. An advantage over the various forms of instantaneous heaters available.
- The Maximiser offers an adjustable limit to the demand from a boiler system that may have other priorities during the year.
- The Maximiser ensures maximum use of the stored volume with no stagnant cold areas normally associated with storage calorifiers.
- The Maximiser with its high output battery and quick response allows considerable saving in floor space over conventional domestic hot water storage systems.
- The Maximiser with its reduced storage volume has a shorter heat-up time from cold requiring less energy input. The standing losses are also less than a conventional storage calorifier; all contributing to energy savings during off peak periods.

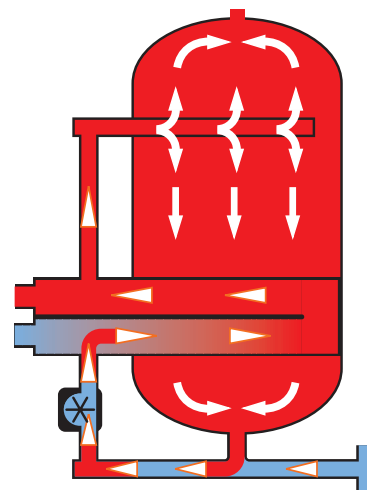

**Fig. 1**  
When the draw off is less than the pump circulation rate all the cold feed is fed straight to the heat exchanger. The pump also takes hot water from the bottom of the cylinder maintaining a full reserve of hot water.

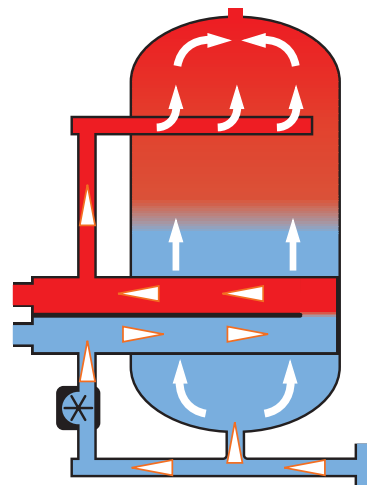

**Fig. 2**  
When the draw off exceeds the pump circulation rate the excess cold water collects in the bottom of the cylinder ready to be passed through the heat exchanger when the peak demand ceases.

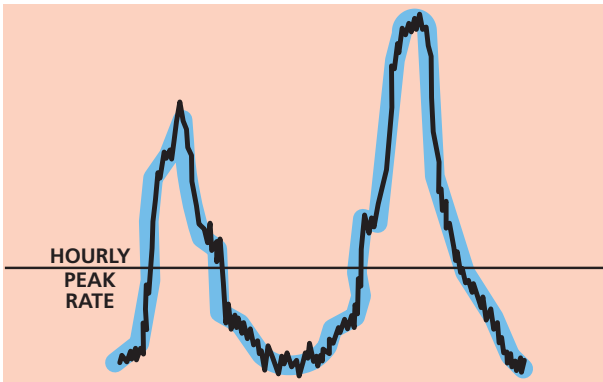

**Fig. 3**  
This pen trace is typical of a fluctuating demand for hot water: sometimes in excess and sometimes less than the hourly peak rate.

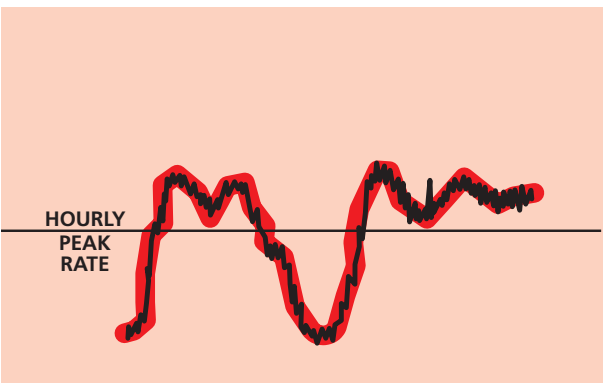

**Fig. 4**  
The response to fluctuating demand by the Maximiser heater is restrained, due to the regulated throughput of the pump.

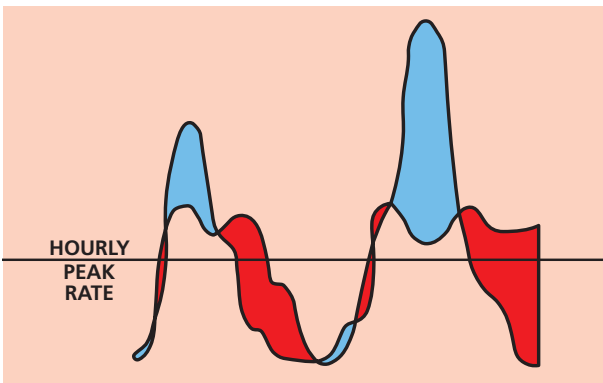

**Fig. 5**  
Combining the two curves helps to illustrate the principle functions of the Maximiser.  
The BLUE areas indicate a period when hot water is drawn from the store and replaced with cold water.  
The RED areas represent a period when the Maximiser is recharging the cylinder with hot water.

## Storage Volume

The optimum storage capacity for the Maximiser is approximately 25% of the peak hourly consumption. This capacity normally provides sufficient buffer volume to cope with the fluctuations in demand while the heat exchanger continues at a steady input.

For some applications the hourly demand is concentrated into a few minutes. Under these conditions either the storage capacity must be increased to meet the full demand or the heat exchanger sized accordingly.

## Flow Distributors

The cold feed connection at the very bottom of the cylinder is fitted with a flow spreader to reduce the incoming velocity and so minimise any disturbance of the hot water. Similarly, discharge from the heat exchanger into the cylinder incorporates a spreader. The secondary flow from the top of the cylinder has a collector to maintain stratification.

## Peak Draw Off

With the aid of the flow distributors there is very little mixing of hot and cold water within the shell. This allows flow rates greatly in excess of the hourly rate for short periods without loss of temperature. Table of Outputs on page 5 gives typical peak flow rates for a maximum period of two minutes.

## Heater Output

The heat exchanger is rated above the hourly demand to provide a margin of cover during sustained periods of heavy draw off. However, the maximum output can be reduced by throttling the pump delivery to the heat exchanger. Since the thermostat maintains a constant flow temperature from the heater, the output is automatically reduced in proportion to the circulation rate.

## Pump Unit

The bronze circulating pump is an integral part of the Maximiser and is independent of any external recirculating system. It is a low head, high output pump designed for low power consumption, continuous operation and is totally enclosed. A flow switch can be supplied to operate a display or alarm system, but this should be requested with the order for incorporation in the pipework.

## Access

An inspection opening is provided on all sizes of Maximiser for examination of the cylinder interior. A single drain valve is so positioned that the entire system can be drained down.

## Heat Exchanger

The heat exchanger comprises a multi-pass U-tube assembly mounted in a 2-pass shell. The heat exchanger shell fits inside the storage cylinder for heat retention and economy of space. The primary medium is contained within the tubes to meet the requirements of BS 853 and accommodates high pressure primary services without undue pressure on the shell side. A bursting disc is fitted on the secondary side for high pressure primary hot water services. The U-tube battery is removable for cleaning and inspection like any conventional storage calorifier. Finned tubes are normally fitted for their compactness and high output but plain tubes are available for hard water applications.

## Control Valve

For primary hot water supply a 3-port valve is normally fitted to minimise pressure and flow changes within the main system. However, for a tight shut off in installations where there are long periods of no draw off and no-circulatory losses, a 2-port valve is recommended.

When steam is the primary medium a 2-port valve is fitted, which is normally sized for critical pressure drop at the design load. This gives finer control over the operating range.

With both forms of heating the valve is controlled by a direct acting thermostat. This is located in the flow pipe from the heat exchanger and the temperature setting is manually adjustable.

## Typical Schematic

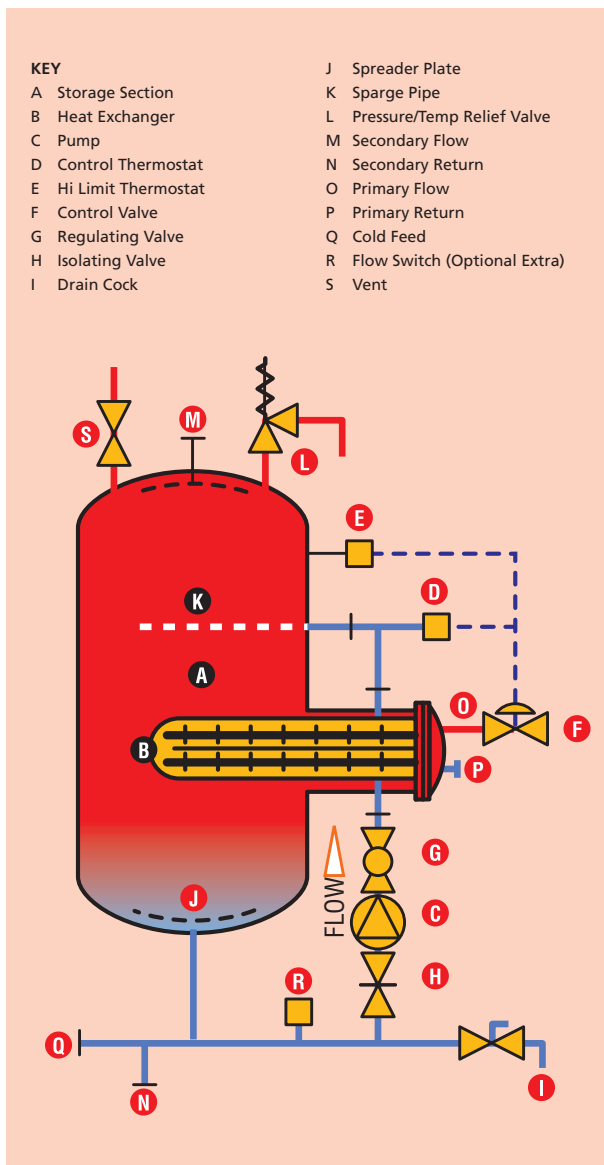

## Safety Controls

Due to the reduced storage capacity of the Maximiser some form of thermal protection is recommended to supplement the temperature control system. The standard Maximiser protection is a temperature/pressure relief valve fitted to the main shell and designed to limit the storage temperature below 100°C.

Additional protection can be provided in the form of a thermal trip on the control valve. Alternatively a completely independent valve can be fitted in series with the control valve to isolate the unit. Both of these systems have adjustable temperature limits. The high temperature sensor is located in the main shell.

Mention has already been made of the pump flow switch. If the high temperature trip is also an electric switch they can be incorporated into an alarm system and form part of the starting sequence.

## Insulation

Standard 'M' type insulation is available which consists of fibreglass mattresses encased in galvanised sheet finished in gloss enamel. Alternative forms of insulation can be fitted on request.

## Condensate Cooling

Due to the high performance of the 2-pass heat exchanger it is possible to offer condensate cooling below 100°C. This cooling takes place in the battery before the steam trap and without any external pipework. Steam consumption is reduced by the amount of additional heat extracted from the condensate. There are no problems with flash steam and heat losses from the condensate return line are reduced.

## Waste Heat Recovery

The Maximiser is an ideal product for recovering heat from a low temperature energy source, such as cooling tower water. A conventional preheat cylinder fitted with an open U-tube battery needs a very large heating surface to be effective. This is because there is only a small temperature difference between the warm primary hot water and the cold storage water. With an open battery heat recovery virtually ceases once the storage temperature is within 10°C of the primary return temperature.

The highly efficient enclosed 2-pass battery of the Maximiser allows much closer approach temperatures to be achieved. With the return pipe from the heat exchanger close to the top of the storage cylinder the maximum benefit is obtained from the waste heat throughout the day.

If waste heat is only available at certain times during the day a differential thermostat can be added to the control system. This will stop and start the Maximiser pump and can be used to divert the primary service if it is below the storage temperature.

# Maximisers – Sizes and Dimensions

## STANDARD CONNECTIONS

- A Primary Flow
- B Primary Return
- C Secondary Flow
- D Secondary Return
- E Cold Feed
- F Thermometer
- G Safety Valve
- H Altitude Gauge
- J Drain
- L Manhole
- M Thermostat x 2
- N Neck NB
- P Lifting Eyes x 2

## ADDITIONAL CONNECTIONS †

- R Vent
  - S Bursting Disc
  - T Anti-Vac Valve
- Other connections available upon request.

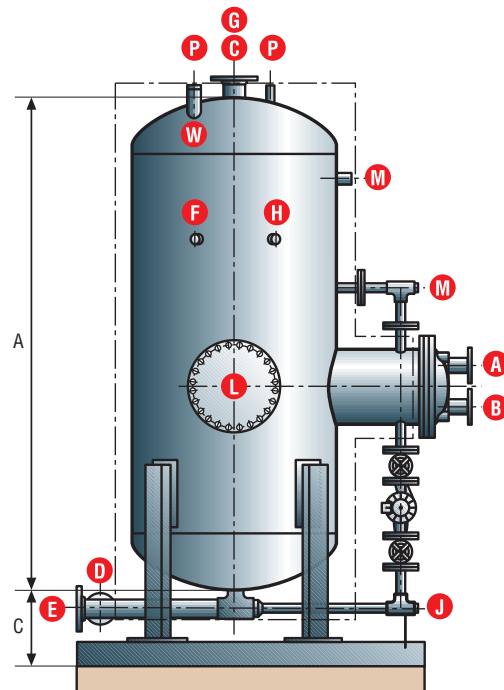
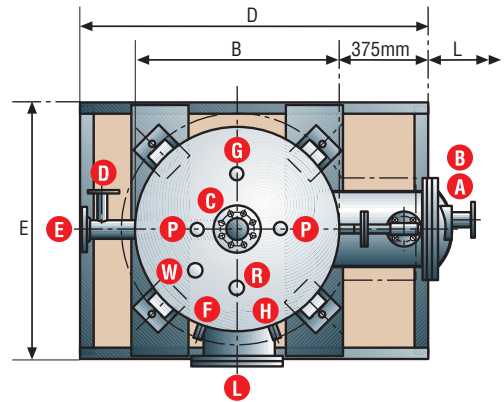
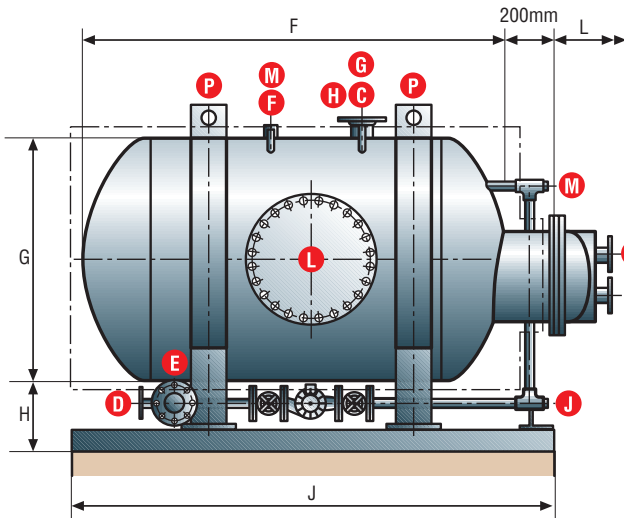
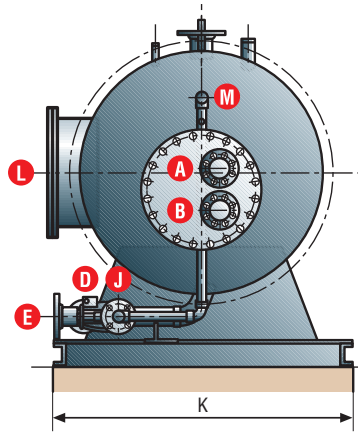

## Dimensions

Unit	Vertical (V)					Horizontal (H)					Battery Withdrawal
	A	B	C	D	E	F	G	H	J	K	
MX440	1850	600	270	1115	840	1430	675	280	1630	915	900
MX550	1750	675	270	1190	915	1400	750	280	1600	990	900
MX700	1800	750	270	1265	990	1450	850	280	1650	1090	900
MX800	2050	750	280	1265	990	1650	850	290	1850	1090	900
MX900	2050	800	280	1315	1040	1650	900	290	1850	1140	1050
MX1000	2000	850	280	1365	1090	1760	900	290	1960	1140	1050
MX1200	2150	900	300	1415	1140	1650	1050	315	1850	1290	950
MX1350	2400	900	300	1415	1140	1850	1050	315	2050	1290	1050
MX1500	1975	1050	300	1565	1290	1700	1150	315	2000	1390	1050
MX1800	2350	1050	340	1565	1290	1900	1200	365	2100	1440	1200
MX2000	2600	1050	340	1565	1290	2100	1200	365	2300	1440	1200
MX2300	2450	1150	340	1665	1390	1950	1350	365	2150	1590	1350
MX2500	2500	1200	340	1715	1440	2100	1350	365	2300	1590	1350
MX3000	3000	1200	405	1715	1440	2450	1350	430	2650	1590	1250
MX3500	2850	1350	405	1865	1590	2450	1450	430	2650	1690	1400
MX4000	3150	1350	405	1865	1590	2740	1450	430	2940	1690	1550
MX4500	3500	1350	480	1865	1590	3050	1450	430	3250	1690	1700

## Connection Size

Unit	Connection Size										Weight (kg)*	
	C	D	E	F	H	J	L	M	R	T	Dry	Wet
MX440	50	25	50	G1/2	G3/8	G3/4	200	G1	G1 1/4	G1	400	850
MX550	50	25	50	G1/2	G3/8	G3/4	250	G1	G1 1/2	G1	405	955
MX700	50	25	50	G1/2	G3/8	G3/4	250	G1	G2	G1	445	1145
MX800	65	25	65	G1/2	G3/8	G3/4	250	G1	G2	G1 1/2	470	1270
MX900	65	25	65	G1/2	G3/8	G3/4	300	G1	G2	G1 1/2	505	1405
MX1000	65	25	65	G1/2	G3/8	G1	300	G1	G2	G1 1/2	590	1590
MX1200	80	32	80	G1/2	G3/8	G1	300	G1	G2	G1 1/2	675	1875
MX1350	80	32	80	G1/2	G3/8	G1	300	G1	G1 1/2	G1 1/2	750	2100
MX1500	80	32	80	G1/2	G3/8	G1	380	G1	G2 1/2	G1 1/2	805	2305
MX1800	100	40	100	G1/2	G3/8	G1	380	G1	G2 1/2	G2	930	2730
MX2000	100	40	100	G1/2	G3/8	G1 1/4	380	G1	G2 1/2	G2	990	2990
MX2300	100	40	100	G1/2	G3/8	G1 1/4	450	G1	G2 1/2	G2	1160	3460
MX2500	100	40	100	G1/2	G3/8	G1 1/4	450	G1	G2 1/2	G2	1215	3715
MX3000	125	50	125	G1/2	G3/8	G1 1/4	450	G1	G2 1/2	G2 1/2	1500	4500
MX3500	125	50	125	G1/2	G3/8	G1 1/4	450	G1	G2 1/2	G2 1/2	1615	5115
MX4000	125	50	125	G1/2	G3/8	G1 1/4	450	G1	G2 1/2	G2 1/2	1775	5775
MX4500	150	65	150	G1/2	G3/8	G1 1/2	450	G1	G2 1/4	G3	2050	6550

The dimensions shown should be used for general information only and are subject to change at Rycroft Ltd discretion. Fully detailed drawings are produced for each order.

\* Weights are approximate and based on copper vessels tested 4 bar. †Additional connections dependent upon Installation and Design parameters.



# Sizing Procedure

There are numerous methods for determining the peak hourly demand for domestic hot water. Whenever possible previous records for plant and equipment should be used to determine the flow rates and if possible their hourly consumption. Where no figures are available the peak hourly demand may be estimated from the data given opposite. Some discretion should be used when applying the load factor, since this may differ considerably with the type of occupation and with seasonal variations.

Having established a peak hourly rate consideration should be given to selecting multiple units instead of a single Maximiser. Multiple units offer additional flexibility and provide back up for emergency conditions.

Two Maximisers each rated at two-third peak demand will allow one unit to be shut down during off peak seasons. It also allows service operations to be performed with minimum inconvenience and provides additional cover for overload situations. With the facility to adjust the pump circulation rate the units can be derated to avoid overloading the boiler when they are both operating.

The Table of Outputs gives the standard maximum hourly demand for the Maximiser range together with the heater input in kW.

The ratings shown apply to our standard range of Maximisers. Maximisers can be designed to meet specific job requirements. Please contact our sales office for further details.

## Table of Outputs

Nominal Capacity litres	Rated Output 10-65°C litres/hour	Heater Rating kW	Peak Draw Off for 2 minutes litres/second
440	1760	135	2.4
550	2200	169	3.0
700	2800	215	3.8
800	3200	246	4.3
900	3600	276	4.9
1000	4000	307	5.4
1200	4800	368	6.5
1350	5400	414	7.3
1500	6000	460	8.3
1800	7200	553	9.8
2000	8000	614	10.8
2300	9200	706	12.5
2500	10000	768	13.5
3000	12000	921	16.3
3500	14000	1075	19.0
4000	16000	1228	21.7
4500	18000	1382	24.4

# Typical Specifications

One vertical 2000 litre high output copper calorifier fitted with an inbuilt heat exchanger, a withdrawable U-tube battery; an integral bronze circulating pump and a load regulator. Rycroft Maximiser reference MXV 2000 capable of 8000 litre/hour of hot water raised from 10 to 65°C. Using steam at 3.5 bar before the control valve and condensate cooled to below 90°C.

Calorifier to be designed and manufactured in accordance with BS 853 Grade A for a secondary open vented system with a working pressure of 2.5 bar and a primary design pressure of 7 bar. To be complete with raised manhole and Rycroft standard 'M' type insulation consisting of 50 mm fibreglass mattress protected by galvanised mild steel casing finished in gloss enamel.

The following fittings to be supplied. Direct acting 2-port thermostatic control valve, steam trap and strainer; temperature/pressure relief valve; rigid stem dial type thermometer, water pressure gauge, steam pressure gauge, drain cock and secondary check valve.

All screwed connections to BS 21.

All flanged connections to BS 4504.

### Materials of construction

Copper sheet to BS 2870/C106

Gunmetal flanges to BS 1400/LG2

Brazing alloy bosses to BS 1400/SCB6

Solid drawn copper finned tubes to BS 2871/C106

Cast-iron chest and joints from compressed asbestos fibre.



# Maximum Demand Rates (litres/hour)

Installation	Private Hand Basin	Public Hand Basin	Shower*	Bath	Slop Sink	Bar Sink	Kitchen Sink	Pantry Sink	Laboratory Sink	Load Factor
Hospital	10	15	70	60	50		80			0.7
Hotel and Residential Hall	10	15	50	50	50	100	80			0.5
Day School	5	20	180		40		80			0.8
Sports Centre	5	15	220		40	100	80			1.0
Restaurant	5	25			100	100	140	120		1.0
University	5	20	220		40		80		40	0.8
Offices	5	10			40		40		40	1.0
Factory	5	20	120		50		80		40	1.0

## Example

200 Bedroom Hotel with Restaurant attached:

200 combined bath/showers	50 x 200	=	10000
200 private handbasins	10 x 200	=	2000
12 public handbasins	15 x 12	=	180
5 Hotel slop sinks	50 x 5	=	250
5 Hotel kitchen sinks	80 x 5	=	400
1 Restaurant slop sink	100 x 1	=	100
4 Restaurant kitchen sinks	140 x 4	=	560
10 Washing Machines 50 l/hr	50 x 10	=	500
	TOTAL	=	13990 l/hr
Load Factor 0.5	Hourly Rate	=	13990 x 0.5
		=	6995 l/hr

By reference to the Table of Outputs it will be seen that the hourly demand for 6995 litres could be handled by a single MX 1800 unit with a maximum output of 7200l/hr. The boiler rating should not be less than 553 kW.

For economic off-peak operation and serviceability, consideration should be given to the choice of TWO Maximisers each 1200 litre capacity.

\* Where a shower and bath are combined in a single cubicle it is only necessary to use one demand rate and the total number of cubicles. Where the shower demand represents the major proportion of an hourly consumption efforts should be made to obtain an accurate estimate of the total usage.

## Example

A factory employs 20 men on dirty work and all take a shower at the end of the shift. If each man uses 50 litres of hot water at 65°C.









Total demand	=	20 x 50
	=	1000 litres
Time taken	=	10 mins
Hourly rate	=	6000 l/hr

## Recognised Standards and Codes of Practice

Maximisers meet the requirements of the following standards and codes of practice:

- National Health Service Model Engineering Specification C07.
- Specification 036 (formerly PSA M&E 3) Heating, hot and cold, steam and gas installations for buildings.
- The control of legionellosis including legionnaires' disease HSG70
- Design, installation, testing and maintenance of services supplying water for domestic use within buildings and their curtilages BS 6700.
- Building Regulations G3 (Unvented Systems).
- Specification for calorifiers and storage vessels for central heating and hot water supply BS 853.
- Health and Safety at Work Act 1974.

Note: Some of these standards and codes pertain to specific installation areas. Please ensure that any relevant standard or code is specified on your enquiry.

-  SUPAPAC Plate Heat Exchangers
-  Shell and Tube Heat Exchangers
-  COMPAC Plate Heat Exchanger Packages
-  MAXIMISER Semi-Storage Calorifiers
-  Calorifiers/Cylinders
-  Unvented Packages
-  Pressurisation
-  Electric Water Heaters
-  Rycroft Process Solutions



**Rycroft**  
HEATING THE WORLD'S WATER

BS EN ISO 9001

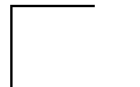

FM No 28819